

Notes:

EXTERNAL WEATHER SEAL

Compressible Impregnated Tape Seal, Size To Suit
Finished Joint In Accordance With Manufacturers
Recommendations

— — — — — DENOTES AIR SEAL LINE

- - - - - DENOTES WEATHERSEAL LINE

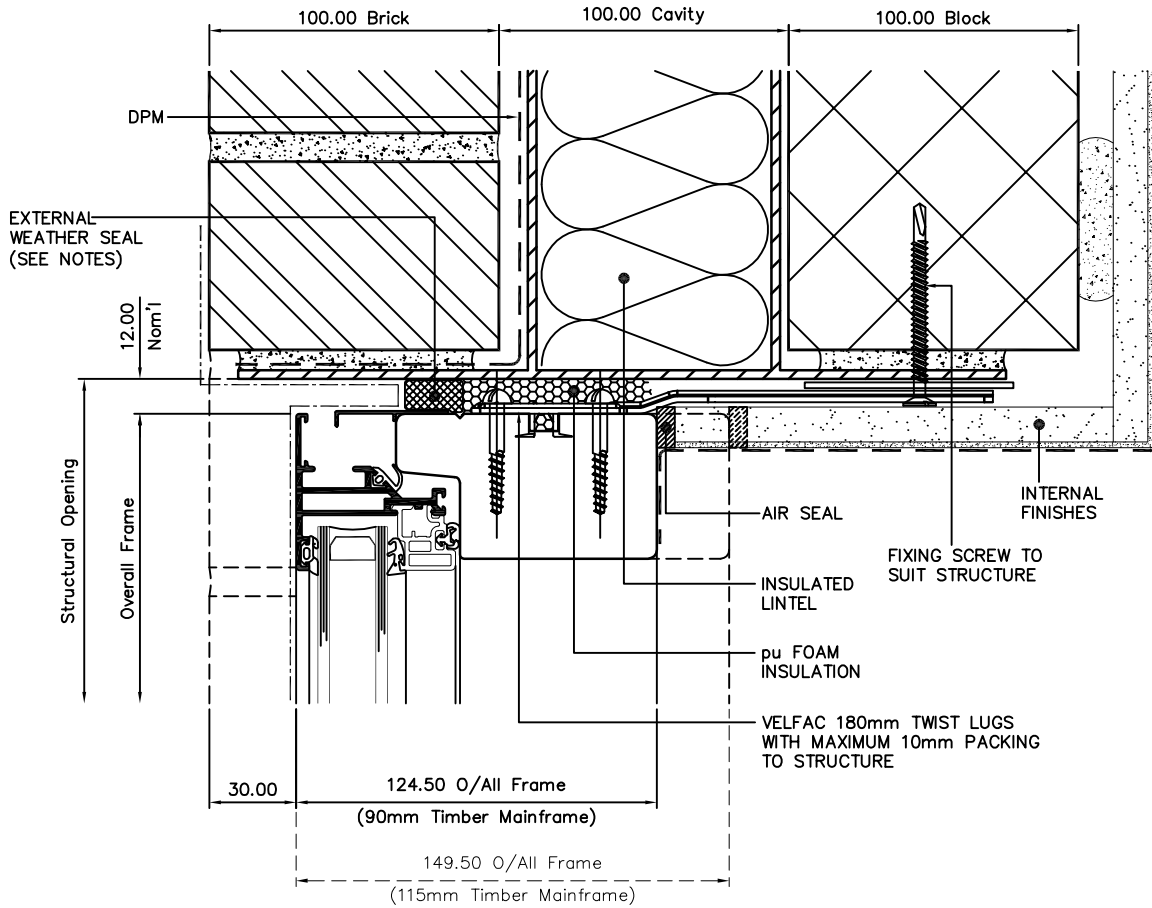
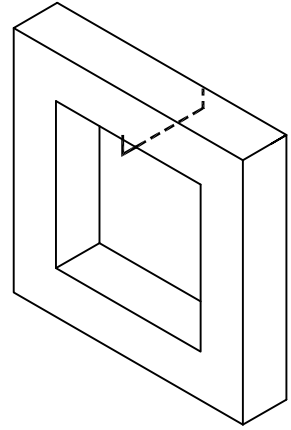

VELFAC Ltd
Tel. +44 1223 897100
Fax. +44 1223 897101
Web. www.VELFAC.co.uk

Title
VELFAC 200 SYSTEM
Typical Brickwork Head Interface
MASONRY CONSTRUCTION

7				Scale.	1:2.5/A4
6				Date.	Feb 10
5				Drawn By.	iDS
4				Checked By.	J.R.
3	03/12	SDS	External weather seal line added	Project No.	-
2	20/10	iDS	VELFAC Twist-In Lug Introduced	Dwg No.	200.Bwk.H001
1	05/10	iDS	1st Issue		
Rev.	Week/Year	Sign.	Description	Edition No.	2

This drawing must not be used or copied without the permission of VELFAC LTD

Notes:

THIS DETAIL APPLICABLE TO TIMBER FRAME BUILDINGS WHERE NO DIFFERENTIAL MOVEMENT WILL BE PRESENT

WHERE DIFFERENTIAL MOVEMENT IS EXPECTED PLEASE CONSULT WITH VELFAC FOR PROJECT-SPECIFIC INTERFACES

EXTERNAL WEATHER SEAL

Compressible Impregnated Tape Seal, Size To Suit Finished Joint In Accordance With Manufacturers Recommendations

— — — — DENOTES AIR SEAL LINE

- - - - - DENOTES WEATHERSEAL LINE

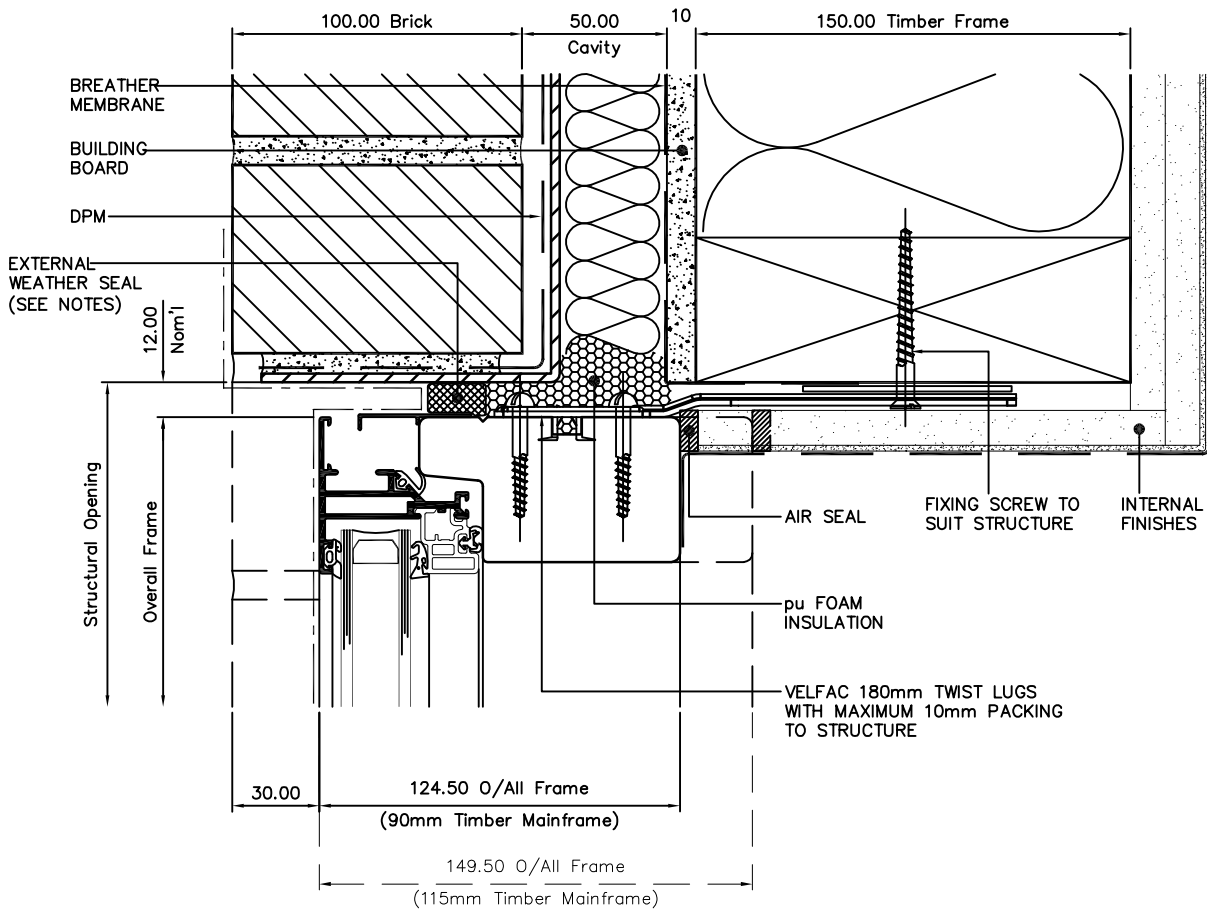
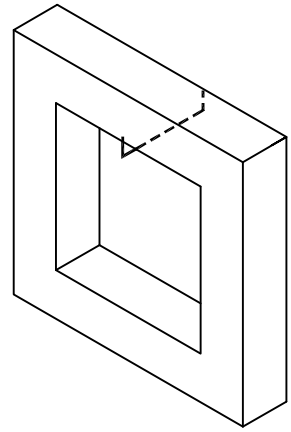

 <p>VELFAC Ltd Tel. +44 1223 897100 Fax. +44 1223 897101 Web. www.VELFAC.co.uk</p>	7				Scale.	1:2.5/A4
	6				Date.	Feb 10
	5				Drawn By.	iDS
	4				Checked By.	J.R.
	3	03/12	SDS	External weather seal line added	Project No.	-
<p>Title</p> <p>VELFAC 200 SYSTEM Typical Brickwork Head Interface TIMBER FRAME CONSTRUCTION</p>	2	20/10	iDS	VELFAC Twist-In Lug Introduced	Dwg No.	200.Bwk.H002
	1	05/10	iDS	1st Issue		
	Rev.	Week/Year	Sign.	Description	Edition No.	2
This drawing must not be used or copied without the permission of VELFAC LTD						

Notes:

Method For Cill Attachment: -

- Apply silicone to attachment profile
- Apply pu foam to brickwork
- Apply cill pressing
- Apply silicone bead at each end of cill to fully seal to structure*

EXTERNAL WEATHER SEAL

Compressible Impregnated Tape Seal, Size To Suit Finished Joint In Accordance With Manufacturers Recommendations

--- DENOTES AIR SEAL LINE

- - - - - DENOTES WEATHERSEAL LINE

Folded Stop Ends

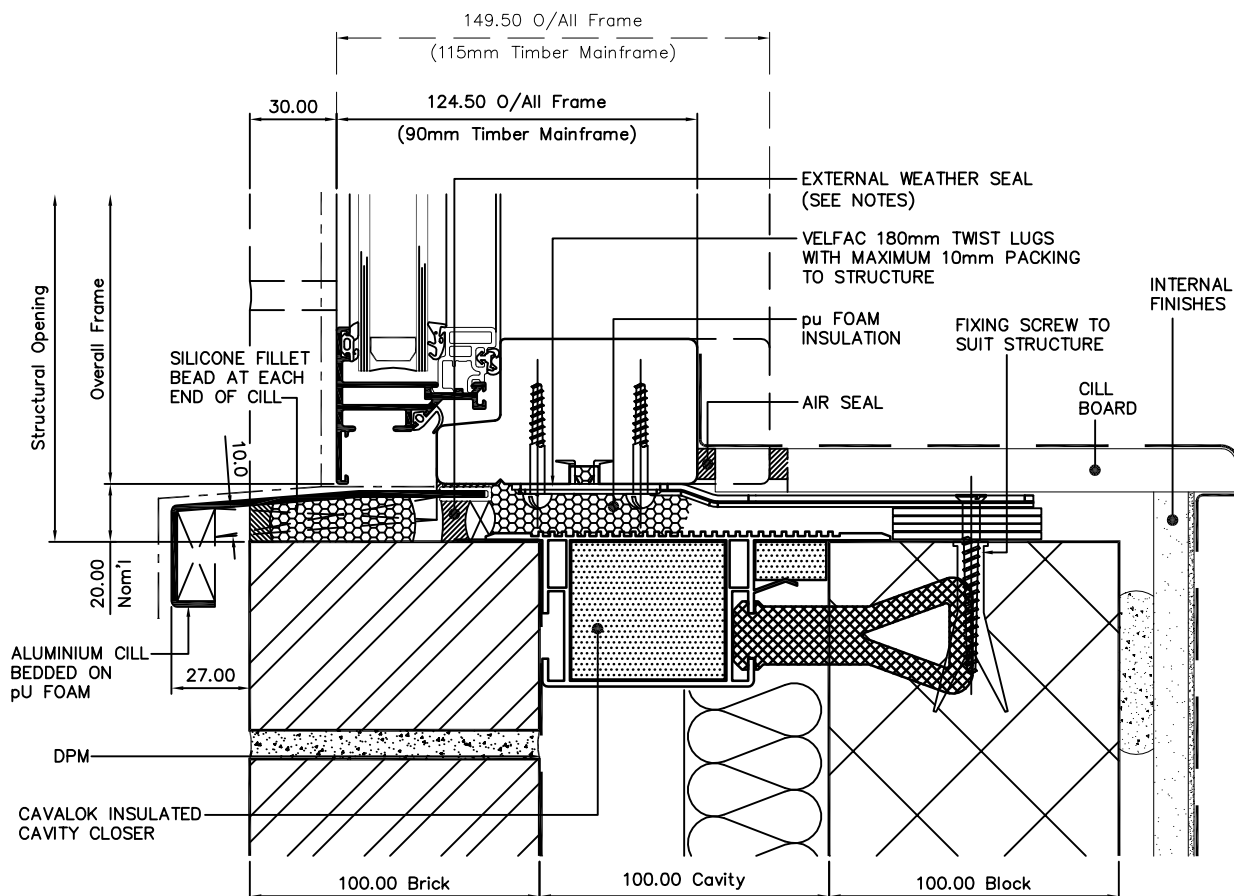
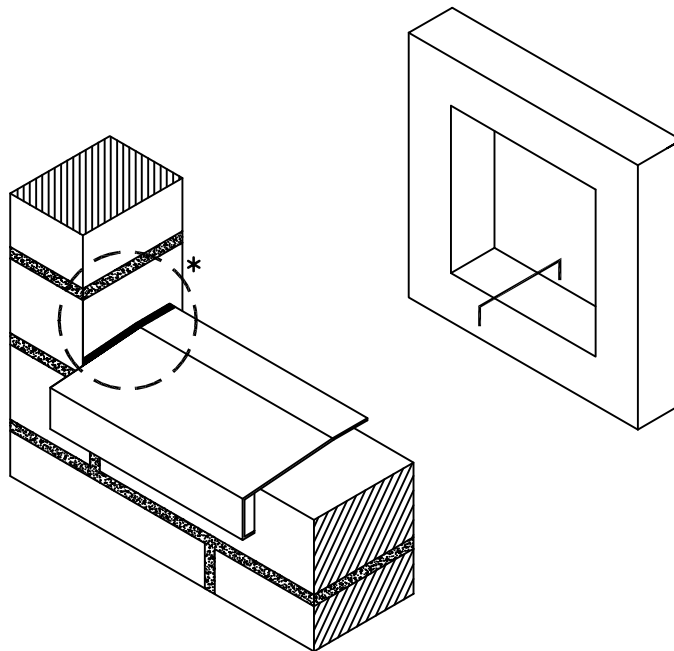
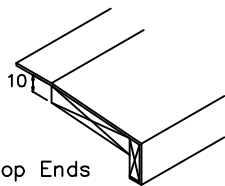

VELFAC Ltd
Tel. +44 1223 897100
Fax. +44 1223 897101
Web. www.VELFAC.co.uk

7				Scale.	1:2.5/A4
6				Date.	Feb 10
5				Drawn By.	iDS
4	03/12	SDS	Folded stop ends added	Checked By.	J.R.
3	01/12	rmr	Tolerance Changed. Stop end profile Rev'd	Project No.	-
2	20/10	iDS	VELFAC Twist-In Lug Introduced	Dwg No.	200 bwk.C001
1	05/10	iDS	1st Issue	Edition No.	3
Rev.	Week/Year	Sign.	Description		

Title
VELFAC 200 SYSTEM
Typical Brickwork Cill Interface With Aluminium Cill
MASONRY CONSTRUCTION

Notes:

EXTERNAL WEATHER SEAL

Compressible Impregnated Tape Seal, Size To Suit
Finished Joint In Accordance With Manufacturers
Recommendations

--- DENOTES AIR SEAL LINE

- - - - - DENOTES WEATHERSEAL LINE

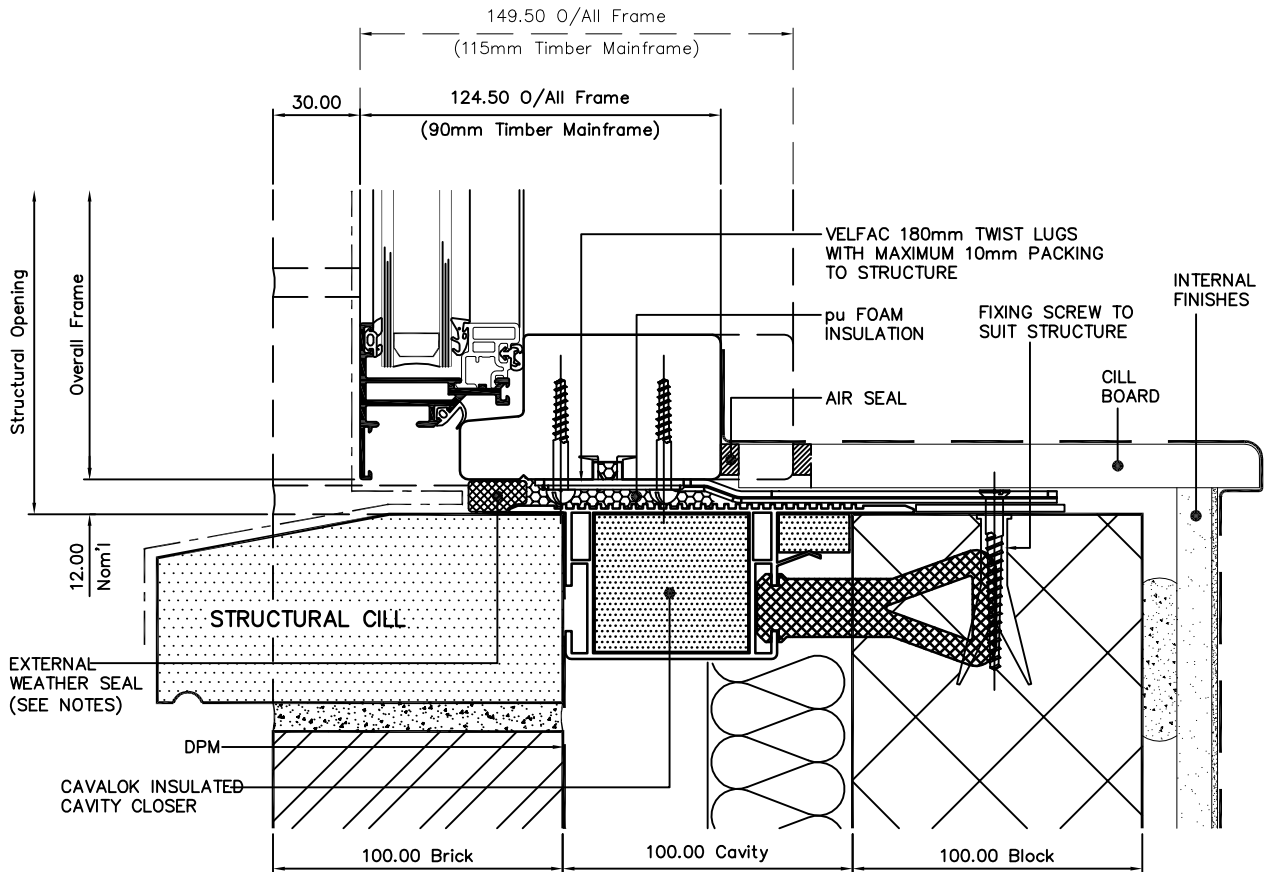
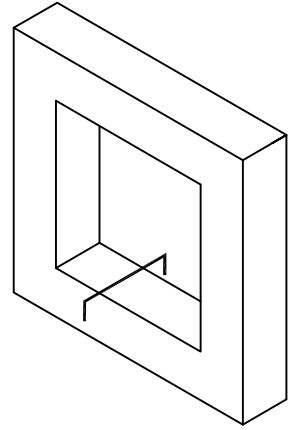

VELFAC Ltd
Tel. +44 1223 897100
Fax. +44 1223 897101
Web. www.VELFAC.co.uk

7				Scale.	1:2.5/A4
6				Date.	Feb 10
5				Drawn By.	IDS
4				Checked By.	J.R.
3	03/12	SDS	External weatherseal line added	Project No.	-
2	20/10	IDS	VELFAC Twist-In Lug Introduced	Dwg No.	
1	05/10	IDS	1st Issue		200.Bwk.C002
Rev.	Week/Year	Sign.	Description	Edition No.	2

Title
VELFAC 200 SYSTEM
Typical Brickwork Cill Interface With Structural Cill
MASONRY CONSTRUCTION

Notes:

THIS DETAIL APPLICABLE TO TIMBER FRAME BUILDINGS WHERE NO DIFFERENTIAL MOVEMENT WILL BE PRESENT

WHERE DIFFERENTIAL MOVEMENT IS EXPECTED PLEASE CONSULT WITH VELFAC FOR PROJECT-SPECIFIC INTERFACES

Method For Cill Attachment: –

- Apply silicone to attachment profile
- Apply pu foam to brickwork
- Apply cill pressing
- Apply silicone bead at each end of cill to fully seal to structure*

EXTERNAL WEATHER SEAL

Compressible Impregnated Tape Seal, Size To Suit Finished Joint In Accordance With Manufacturers Recommendations

- DENOTES AIR SEAL LINE
- - - - - DENOTES WEATHERSEAL LINE

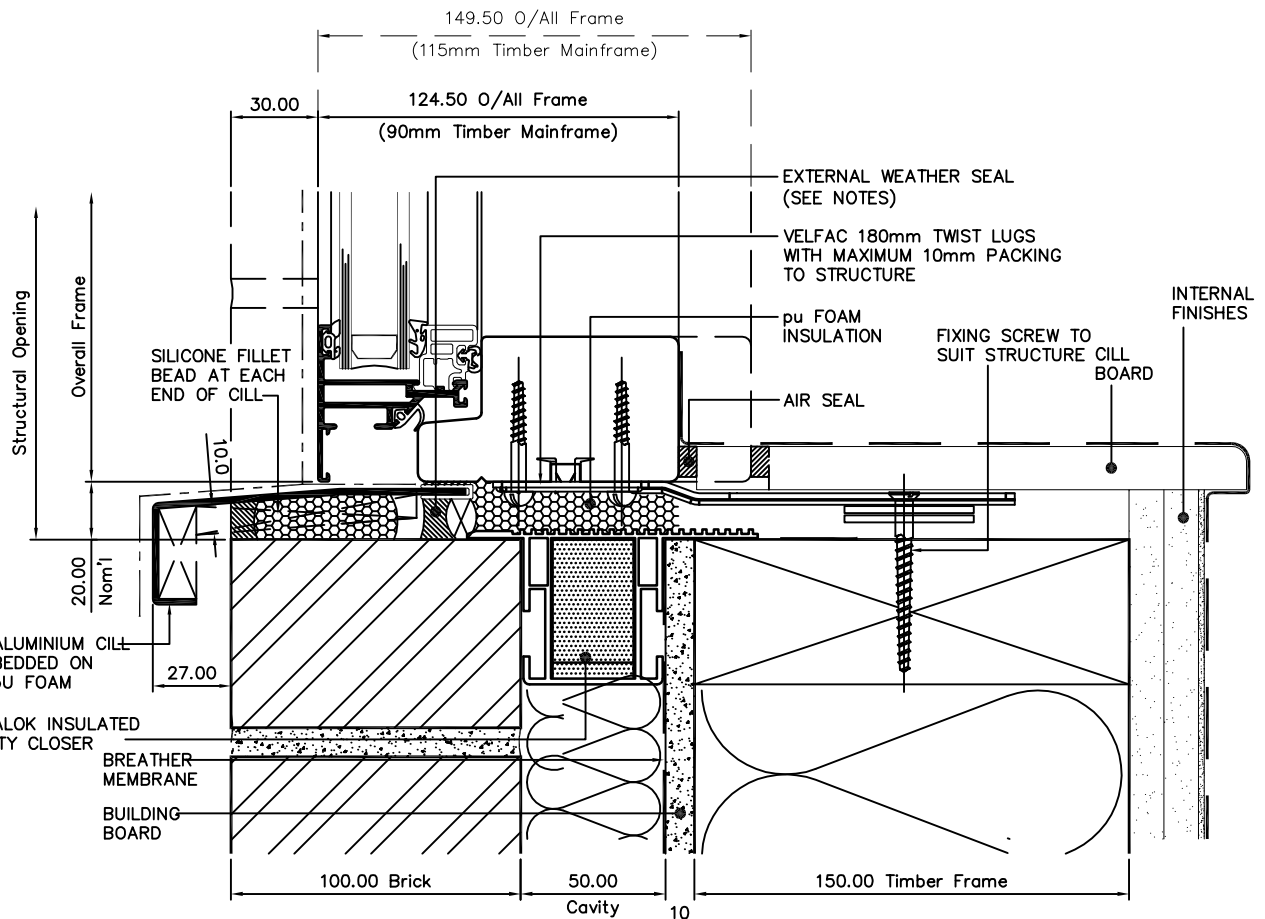
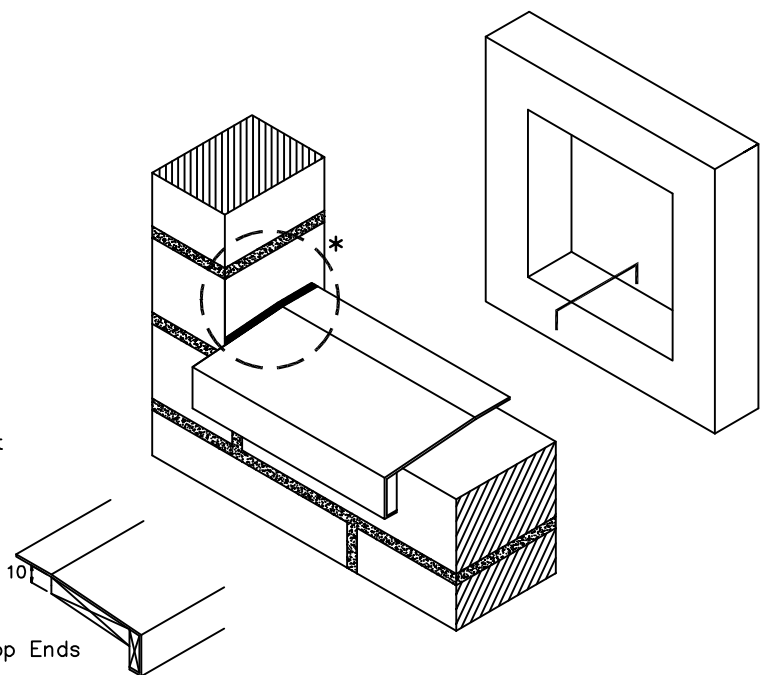

VELFAC Ltd
Tel. +44 1223 897100
Fax. +44 1223 897101
Web. www.VELFAC.co.uk

7				Scale.	1:2.5/A4
6				Date.	Feb 10
5				Drawn By.	IDS
4				Checked By.	J.R.
3	03/12	SDS	Ext.weatherseal,Folded stop ends,20mm tol	Project No.	-
2	20/10	IDS	VELFAC Twist-In Lug Introduced	Dwg No.	200.Bwk.C003
1	05/10	IDS	1st Issue		
Rev.	Week/Year	Sign.	Description	Edition No.	2

Title

VELFAC 200 SYSTEM
Typical Brickwork Cill Interface With Aluminium Cill
TIMBER FRAME CONSTRUCTION

Notes:

THIS DETAIL APPLICABLE TO TIMBER FRAME BUILDINGS WHERE NO DIFFERENTIAL MOVEMENT WILL BE PRESENT

WHERE DIFFERENTIAL MOVEMENT IS EXPECTED PLEASE CONSULT WITH VELFAC FOR PROJECT-SPECIFIC INTERFACES

EXTERNAL WEATHER SEAL

Compressible Impregnated Tape Seal, Size To Suit Finished Joint In Accordance With Manufacturers Recommendations

— — — — DENOTES AIR SEAL LINE

- - - - - DENOTES WEATHERSEAL LINE

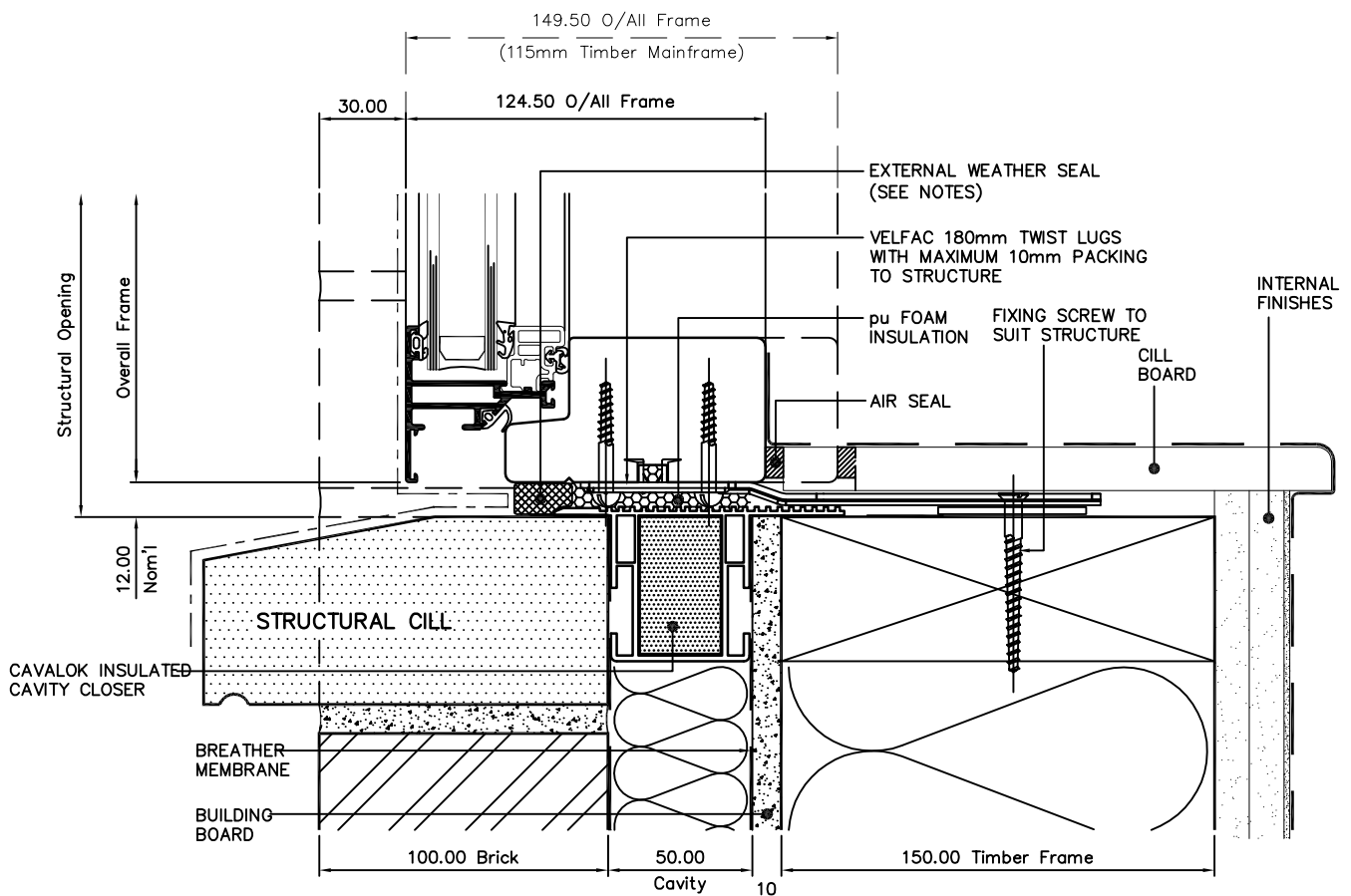
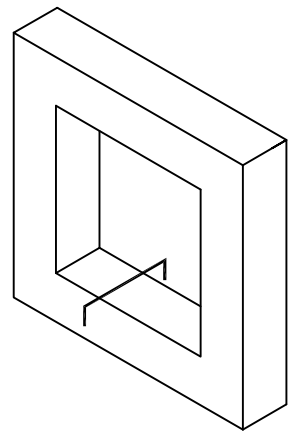

	VELFAC Ltd Tel. +44 1223 897100 Fax. +44 1223 897101 Web. www.VELFAC.co.uk			7			Scale.	1:2.5/A4
				6			Date.	Feb 10
			5			Drawn By.	IDS	
			4			Checked By.	J.R.	
Title VELFAC 200 SYSTEM Typical Brickwork Cill Interface With Structural Cill TIMBER FRAME CONSTRUCTION			3	03/12	SDS	External weather seal line added	Project No.	-
			2	20/10	IDS	VELFAC Twist-In Lug Introduced	Dwg No.	200.Bwk.C004
			1	05/10	IDS	1st Issue	Edition No.	2
			Rev.	Week/Year	Sign.	Description		
This drawing must not be used or copied without the permission of VELFAC LTD								

Notes:

EXTERNAL WEATHER SEAL

Compressible Impregnated Tape Seal,
Size To Suit Finished Joint In
Accordance With Manufacturers
Recommendations

- DENOTES AIR SEAL LINE
- - - - - DENOTES WEATHERSEAL LINE

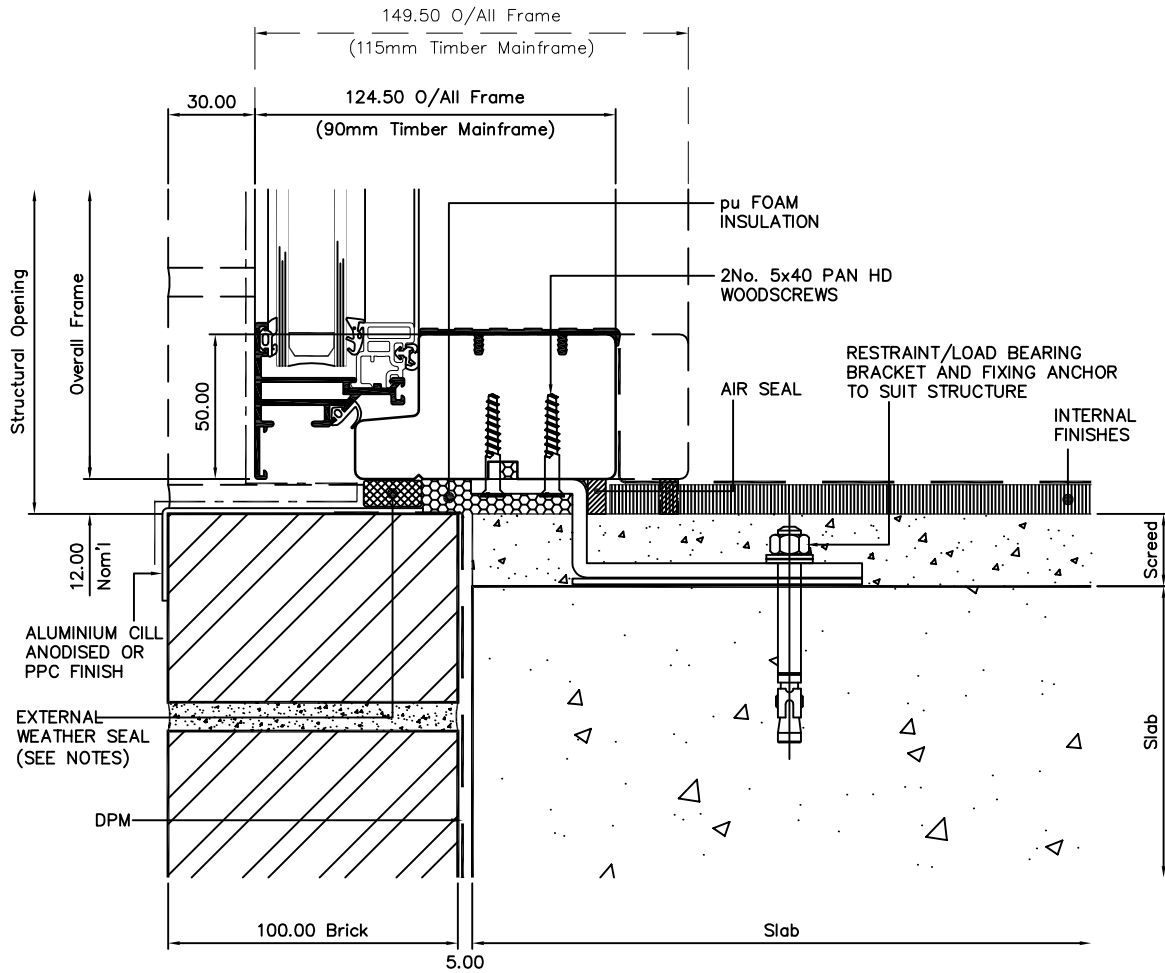
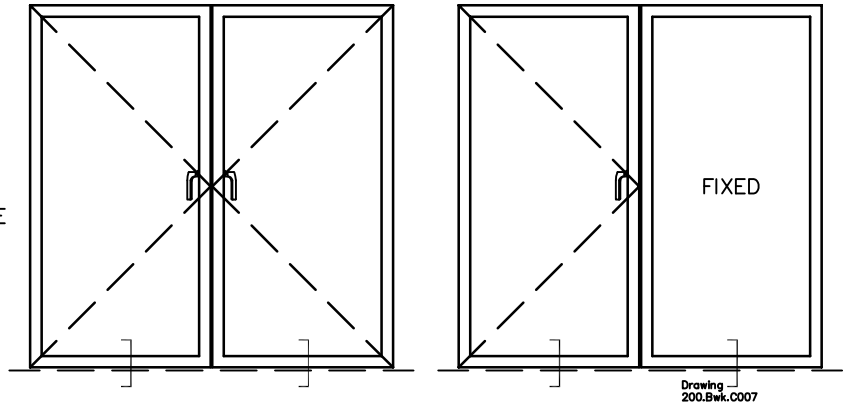

VELFAC Ltd
Tel. +44 1223 897100
Fax. +44 1223 897101
Web. www.VELFAC.co.uk

7				Scale.	1:2.5/A4
6				Date.	Feb 10
5				Drawn By.	IDS
4				Checked By.	J.R.
3				Project No.	-
2	03/12	SDS	External weather seal line added	Dwg No.	200.Bwk.C005
1	05/10	IDS	1st Issue		
Rev.	Week/Year	Sign.	Description	Edition No.	1

Title
VELFAC 200 SYSTEM
Typical Patio Door Threshold Interface

NOTE:
This Detail Can Be Used In Conjunction With Typical
Low Level Cill Interface 200.Bwk.C007

This drawing must not be used or copied without the permission of VELFAC LTD

Notes:

- — — — — DENOTES AIR SEAL LINE
- - - - - DENOTES WEATHERSEAL LINE

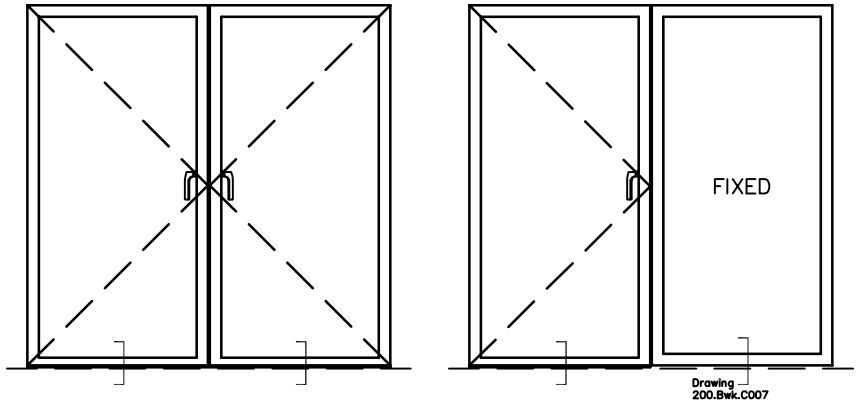

Drawing -
200.Bwk.C007

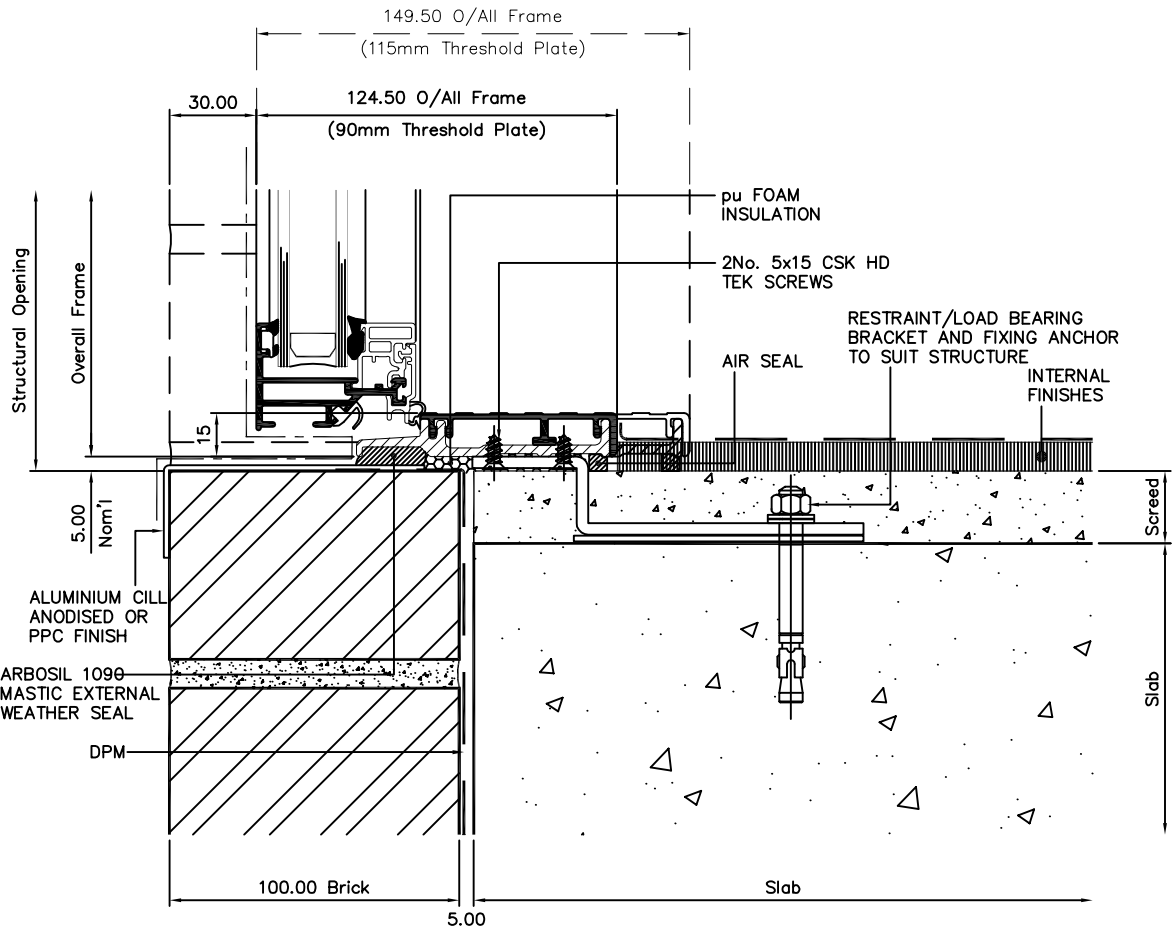

VELFAC Ltd
Tel. +44 1223 897100
Fax. +44 1223 897101
Web. www.VELFAC.co.uk

7				Scale.	1:2.5/A4
6				Date.	Feb 10
5				Drawn By.	IDS
4				Checked By.	J.R.
3				Project No.	-
2	03/12	SDS	External weather seal line added	Dwg No.	200.Bwk.C006
1	05/10	IDS	1st Issue		
Rev.	Week/Year	Sign.	Description	Edition No.	1

Title
VELFAC 200 SYSTEM
Typical Patio Door Low Threshold Interface

NOTE:
This Detail Can Be Used In Conjunction With Typical
Low Level Cill Interface 200.Bwk.C007

This drawing must not be used or copied without the permission of VELFAC LTD

Notes:

EXTERNAL WEATHER SEAL

Compressible Impregnated Tape Seal,
Size To Suit Finished Joint In
Accordance With Manufacturers
Recommendations

- DENOTES AIR SEAL LINE
- - - - - DENOTES WEATHERSEAL LINE

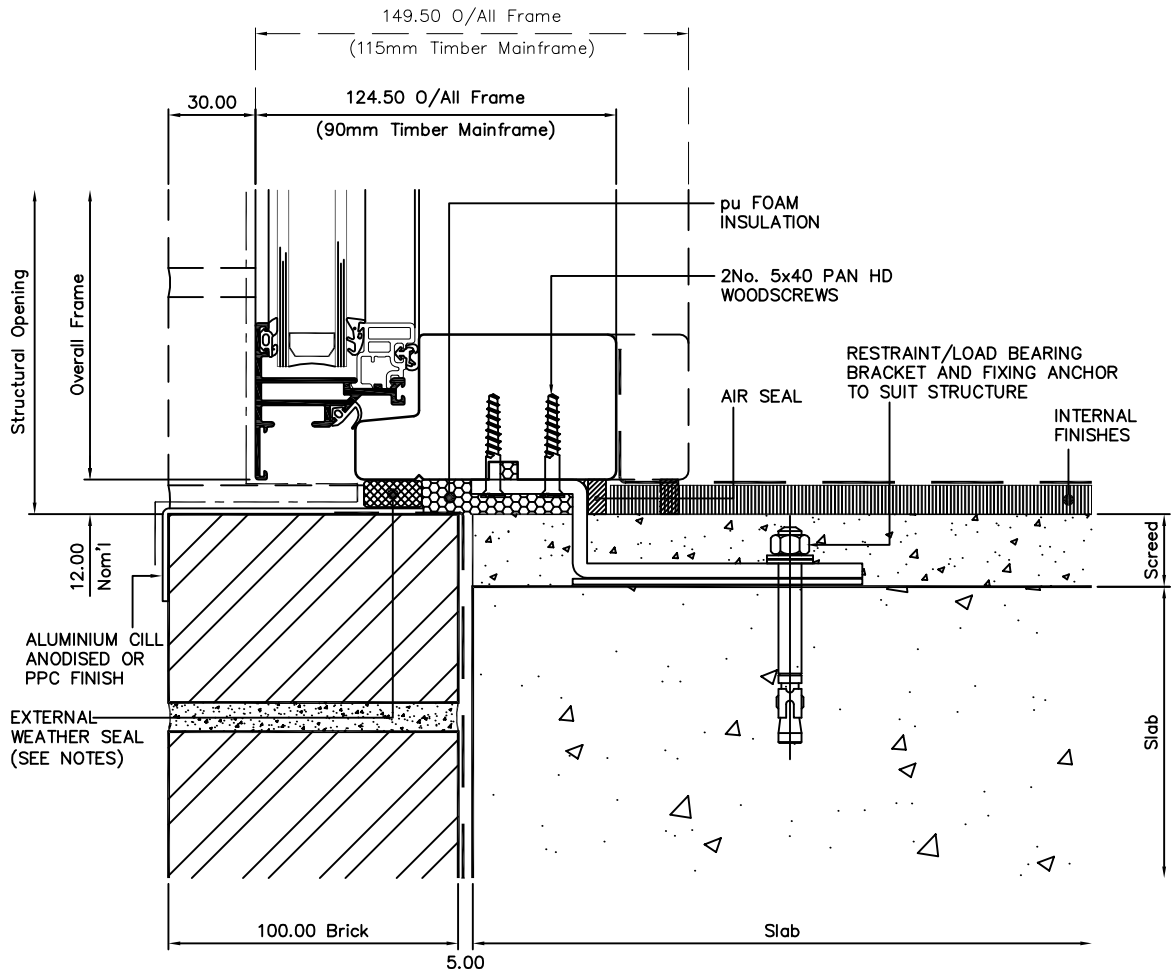
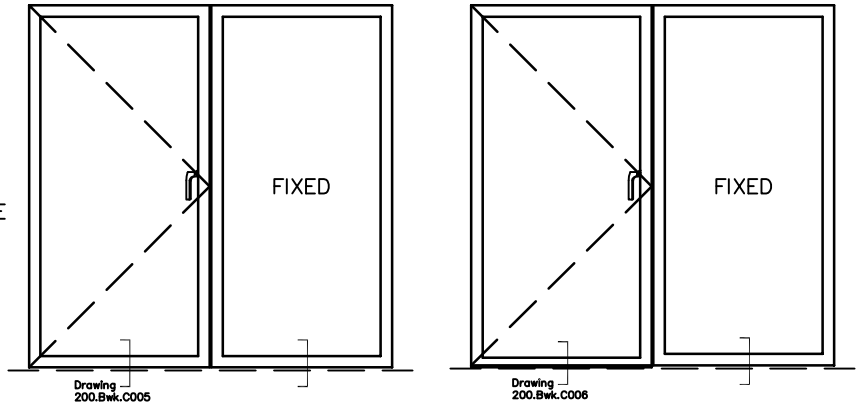

VELFAC Ltd
Tel. +44 1223 897100
Fax. +44 1223 897101
Web. www.VELFAC.co.uk

Title

VELFAC 200 SYSTEM
Typical Low Level Cill Interface

NOTE: This Detail Can Be Used In Conjunction With
Typical Patio Door Threshold/Low Threshold Interfaces
200.Bwk.C005 & 200.Bwk.C006

7				Scale.	1:2.5/A4
6				Date.	Feb 10
5				Drawn By.	IDS
4				Checked By.	J.R.
3				Project No.	-
2	03/12	SDS	External weather seal line added	Dwg No.	200.Bwk.C007
1	05/10	IDS	1st Issue		
Rev.	Week/Year	Sign.	Description	Edition No.	1

This drawing must not be used or copied without the permission of VELFAC LTD

Notes:

- DENOTES AIR SEAL LINE
- - - - - DENOTES WEATHERSEAL LINE

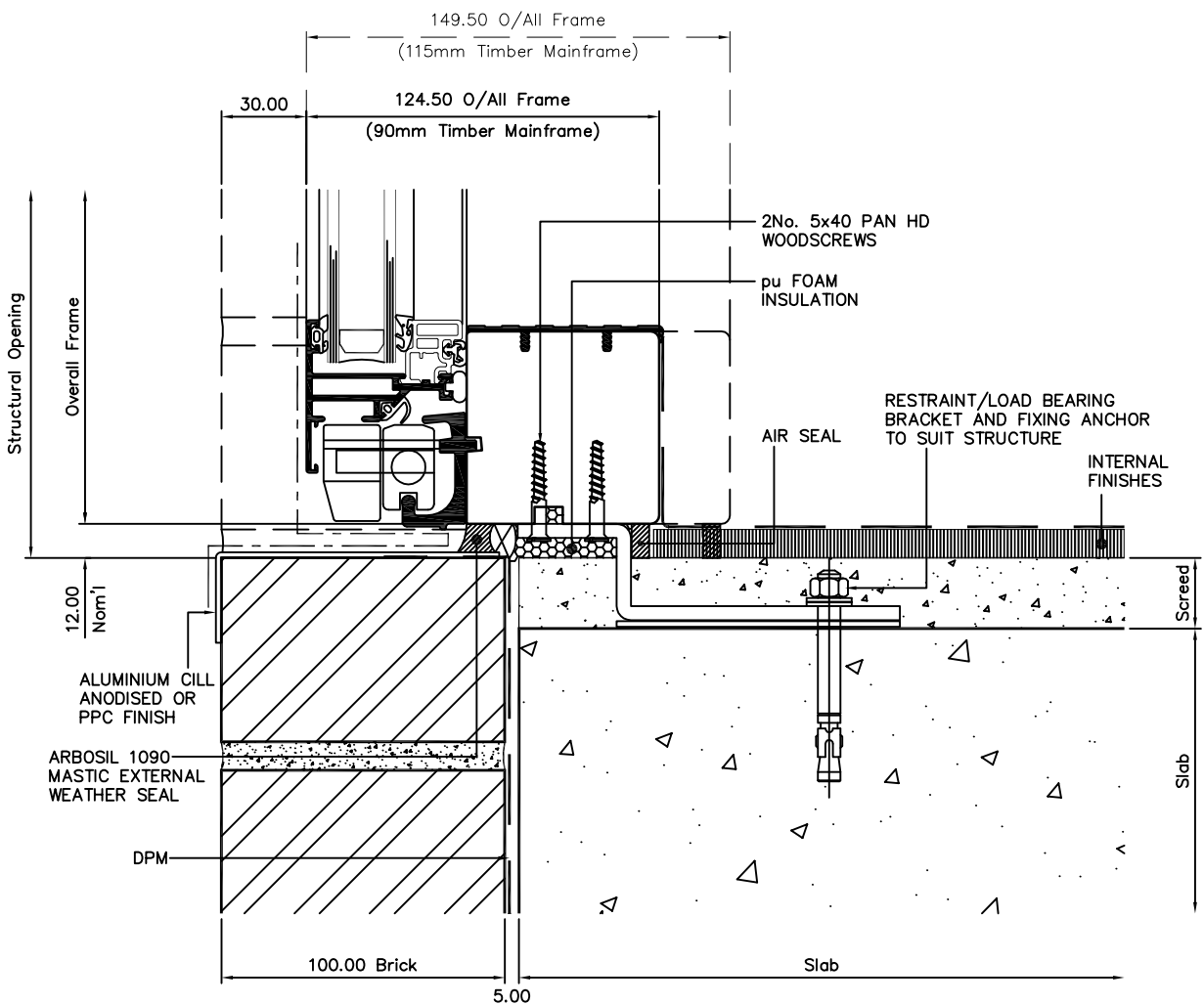

VELFAC Ltd
Tel. +44 1223 897100
Fax. +44 1223 897101
Web. www.VELFAC.co.uk

Title
VELFAC 200 SYSTEM
Typical Sliding Door Threshold Interface

NOTE:
This Detail To Be Used In Conjunction With Typical
Sliding Door Sidelight Cill Interface 200.Bwk.C009

7				Scale.	1:2.5/A4
6				Date.	Feb 10
5				Drawn By.	IDS
4				Checked By.	J.R.
3				Project No.	-
2	03/12	SDS	External weather seal line added	Dwg No.	200.Bwk.C008
1	05/10	IDS	1st Issue		
Rev.	Week/Year	Sign.	Description	Edition No.	1

This drawing must not be used or copied without the permission of VELFAC LTD

Notes:

- DENOTES AIR SEAL LINE
- - - - DENOTES WEATHERSEAL LINE

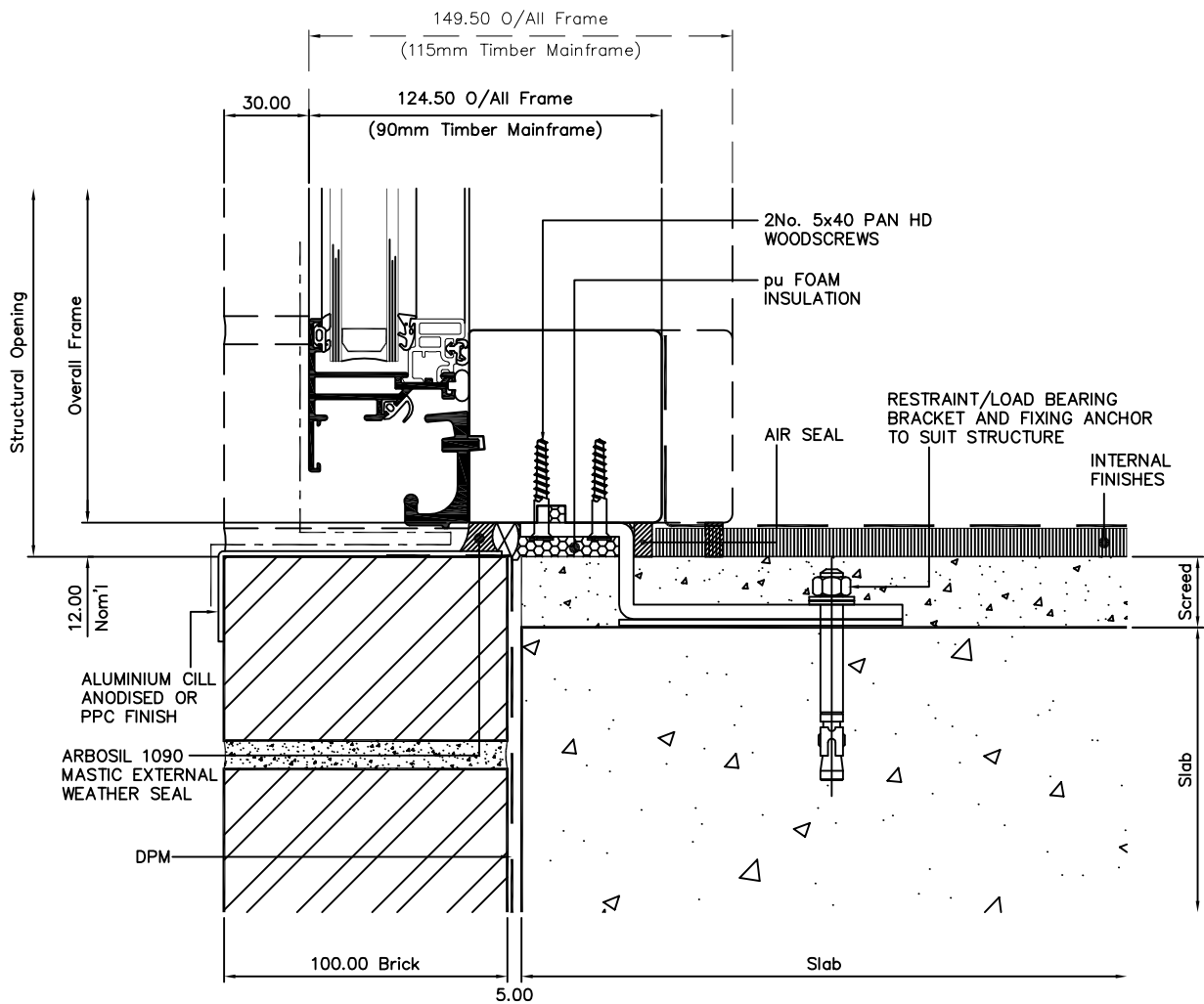

VELFAC Ltd
Tel. +44 1223 897100
Fax. +44 1223 897101
Web. www.VELFAC.co.uk

Title

VELFAC 200 SYSTEM
Typical Sliding Door Sidelight Cill Interface

NOTE:
This Detail To Be Used In Conjunction With Typical
Sliding Door Threshold Interface 200.Bwk.C008

7				Scale.	1:2.5/A4
6				Date.	Feb 10
5				Drawn By.	IDS
4				Checked By.	J.R.
3				Project No.	-
2	03/12	SDS	External weather seal line added	Dwg No.	200.Bwk.C009
1	05/10	IDS	1st Issue	Edition No.	
Rev.	Week/Year	Sign.	Description		1

This drawing must not be used or copied without the permission of VELFAC LTD

Notes:

- DENOTES AIR SEAL LINE
- - - - - DENOTES WEATHERSEAL LINE

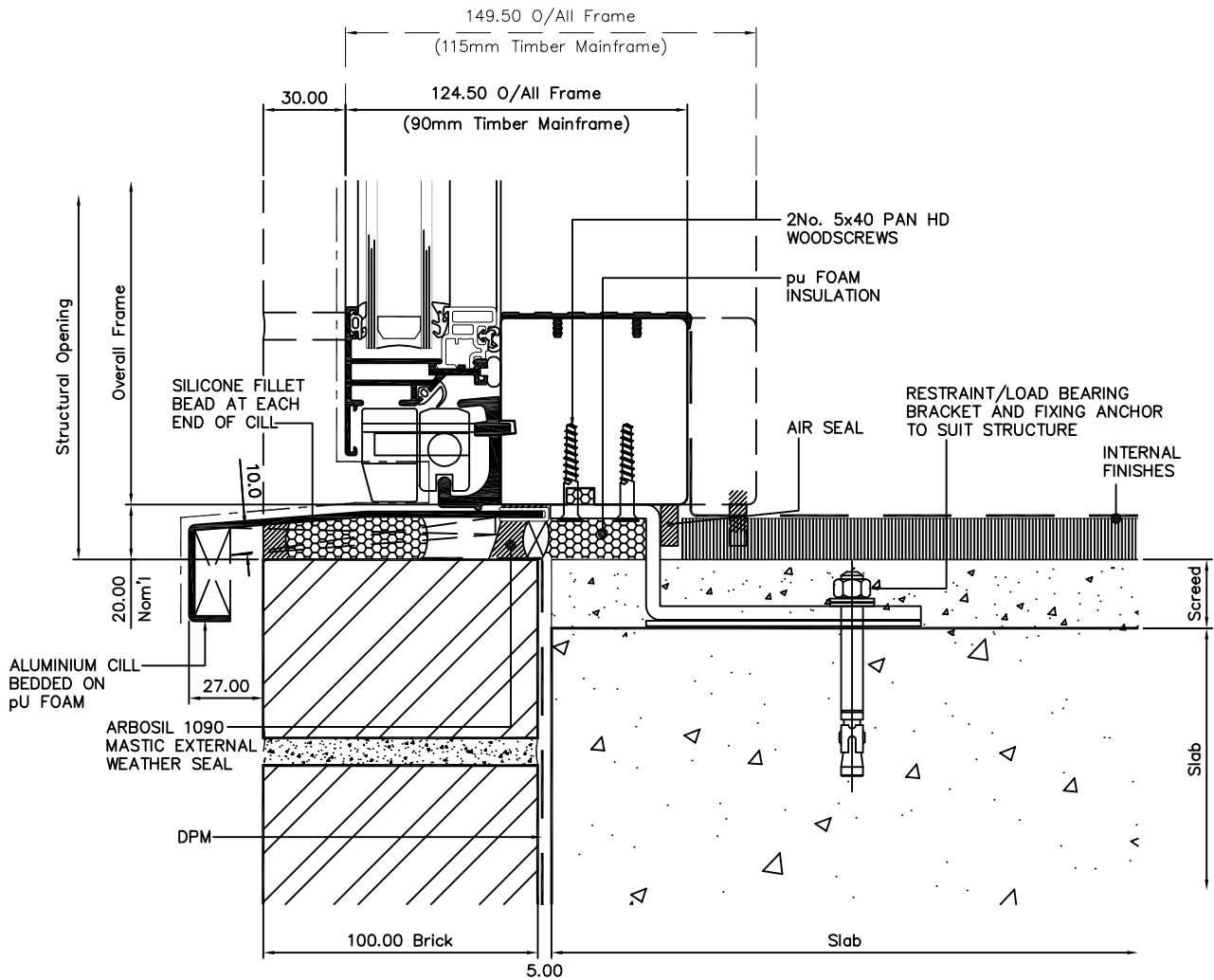

VELFAC Ltd
 Tel. +44 1223 897100
 Fax. +44 1223 897101
 Web. www.VELFAC.co.uk

7				Scale.	1:2.5/A4
6				Date.	Feb 10
5				Drawn By.	IDS
4				Checked By.	J.R.
3				Project No.	-
2	03/12	SDS	Ext.weatherseal,Folded stop ends,20mm tol	Dwg No.	200.Bwk.C010
1	05/10	IDS	1st Issue	Edition No.	1
Rev.	Week/Year	Sign.	Description		

Title
 VELFAC 200 SYSTEM
 Typical Sliding Door Threshold Interface With Alu. Cill

NOTE:
 This Detail To Be Used In Conjunction With Typical
 Sliding Door Sidelight Cill Interface 200.Bwk.C011

Notes:

- DENOTES AIR SEAL LINE
- - - - DENOTES WEATHERSEAL LINE

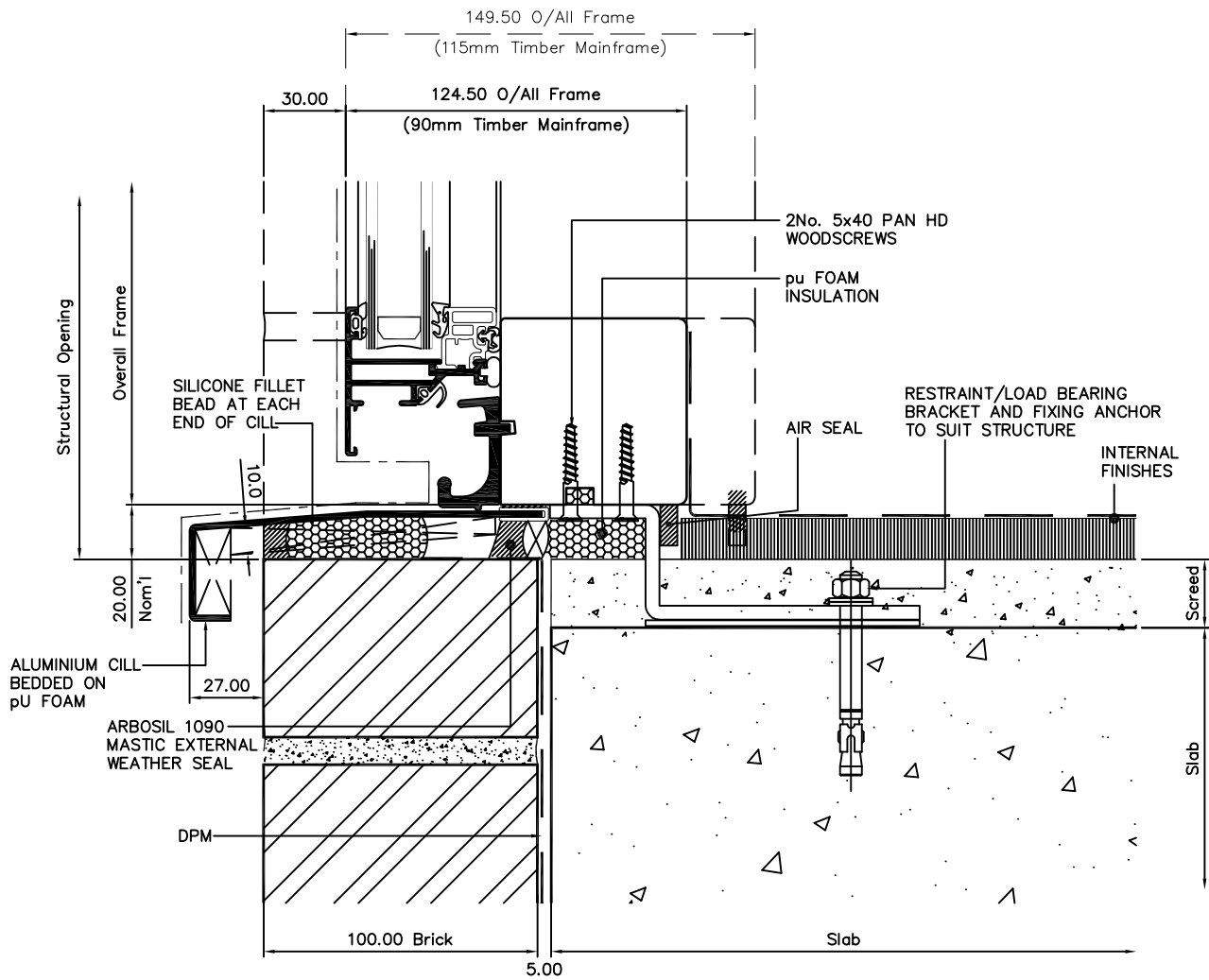
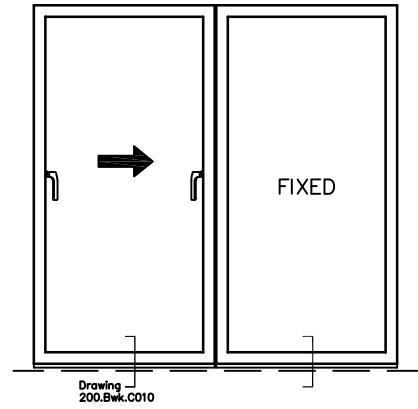

VELFAC Ltd
Tel. +44 1223 897100
Fax. +44 1223 897101
Web. www.VELFAC.co.uk

7				Scale.	1:2.5/A4
6				Date.	Feb 10
5				Drawn By.	IDS
4				Checked By.	J.R.
3				Project No.	-
2	03/12	SDS	Ext.weatherseal,Folded stop ends,20mm tol	Dwg No.	200.Bwk.C011
1	05/10	IDS	1st Issue		
Rev.	Week/Year	Sign.	Description	Edition No.	1

Title
VELFAC 200 SYSTEM
Typical Sliding Door Sidelight Cill Interface With Alu. Cill

NOTE:
This Detail To Be Used In Conjunction With Typical
Sliding Door Threshold Interface 200.Bwk.C010

Notes:

EXTERNAL WEATHER SEAL

Compressible Impregnated Tape Seal, Size To Suit
Finished Joint In Accordance With Manufacturers
Recommendations

— — — — — DENOTES AIR SEAL LINE

- - - - - DENOTES WEATHERSEAL LINE

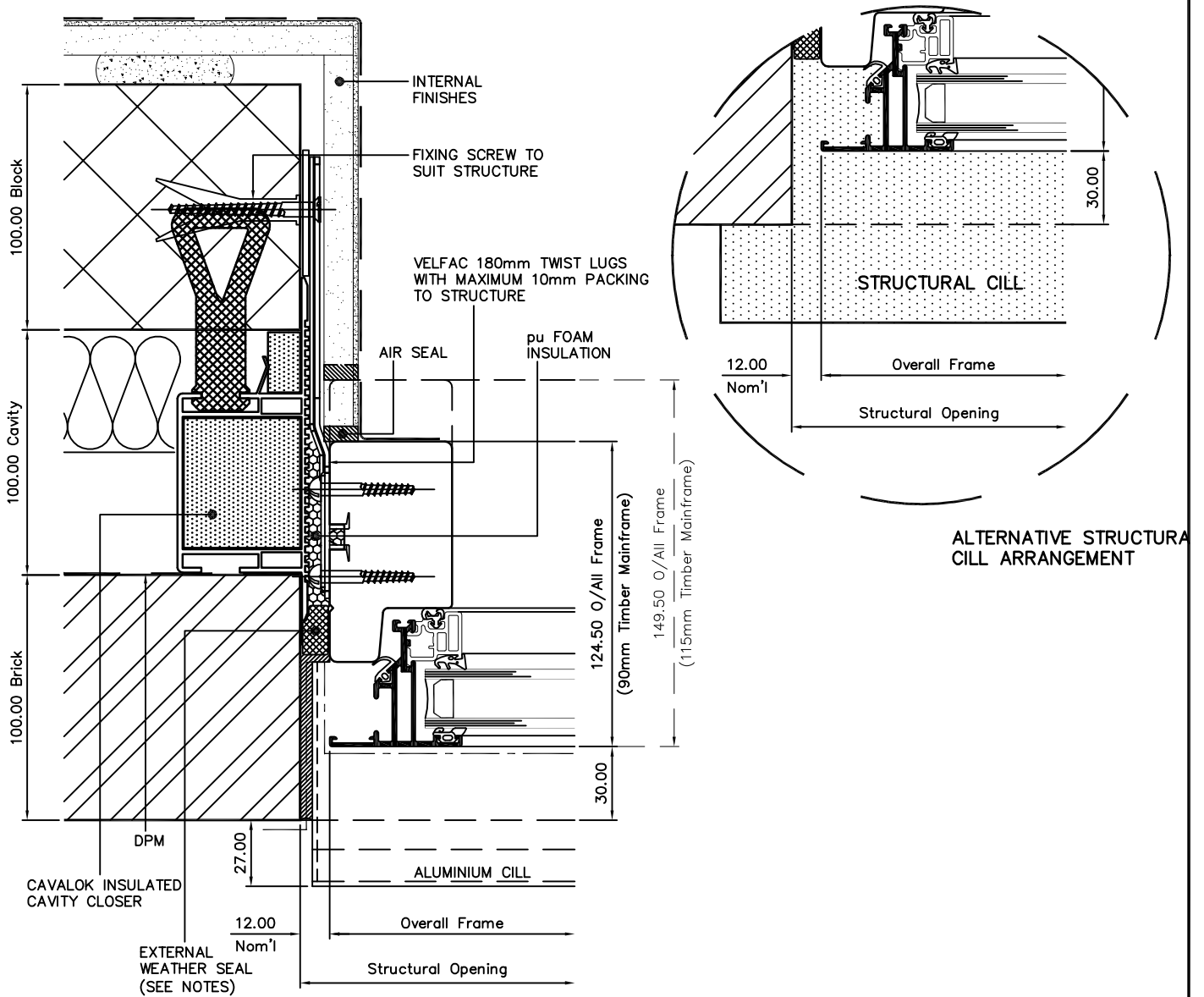
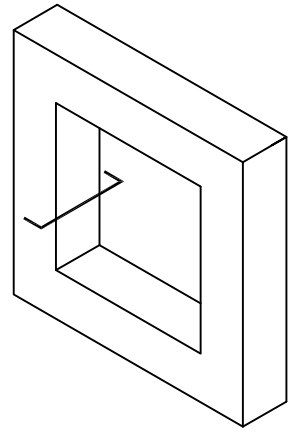

VELFAC Ltd
Tel. +44 1223 897100
Fax. +44 1223 897101
Web. www.VELFAC.co.uk

7				Scale.	1:2.5/A4
6				Date.	Feb 10
5				Drawn By.	IDS
4				Checked By.	J.R.
3	03/12	SDS	External weatherseal, cill downstand	Project No.	-
2	20/10	IDS	VELFAC Twist-In Lug Introduced	Dwg No.	
1	05/10	IDS	1st Issue		200.Bwk.J001
Rev.	Week/Year	Sign.	Description	Edition No.	2

Title
VELFAC 200 SYSTEM
Typical Brickwork Jamb Interfaces
MASONRY CONSTRUCTION

Notes:

THIS DETAIL APPLICABLE TO TIMBER FRAME BUILDINGS WHERE NO DIFFERENTIAL MOVEMENT WILL BE PRESENT

WHERE DIFFERENTIAL MOVEMENT IS EXPECTED PLEASE CONSULT WITH VELFAC FOR PROJECT-SPECIFIC INTERFACES

EXTERNAL WEATHER SEAL

Compressible Impregnated Tape Seal, Size To Suit Finished Joint In Accordance With Manufacturers Recommendations

--- DENOTES AIR SEAL LINE

- - - - - DENOTES WEATHERSEAL LINE

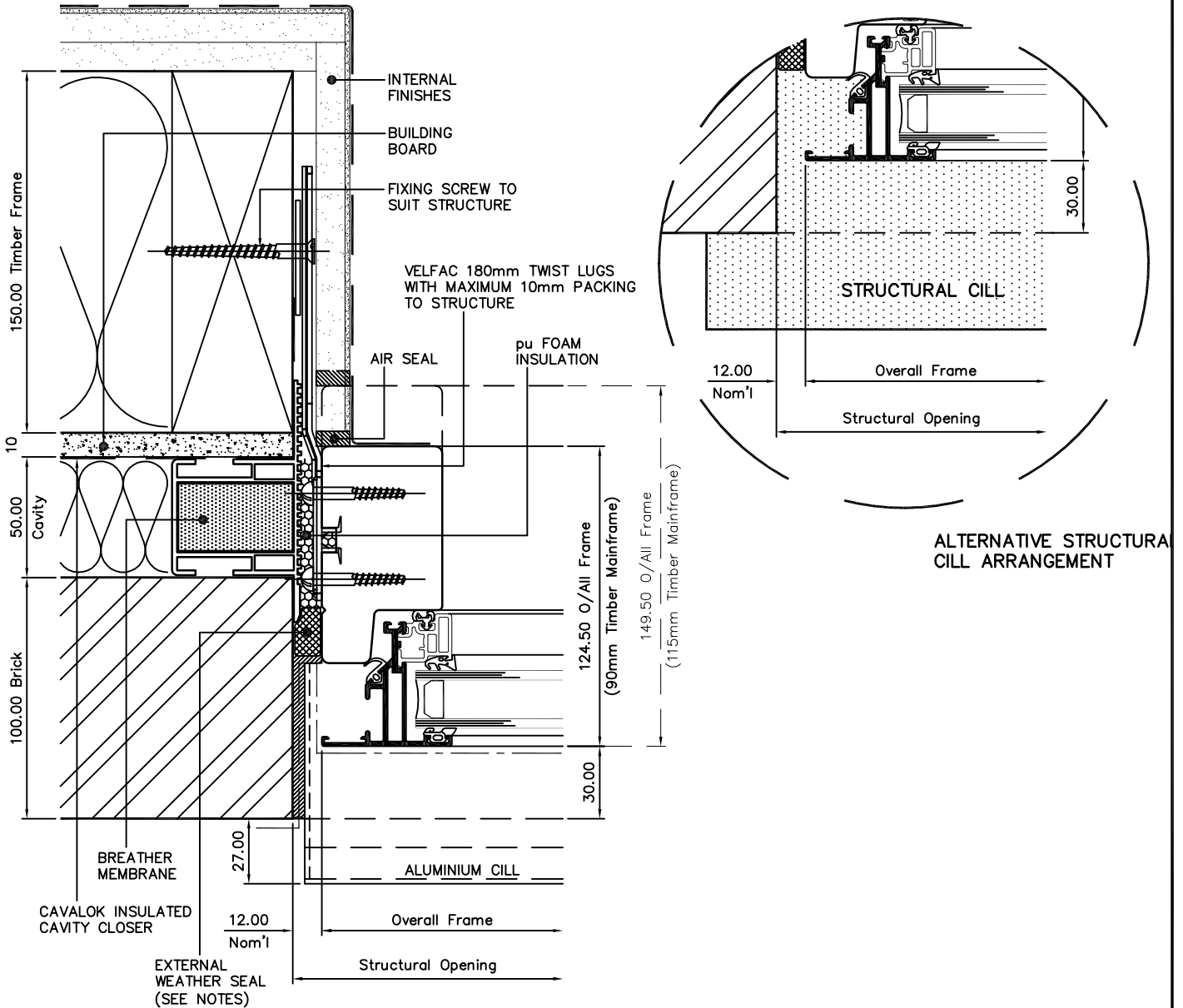
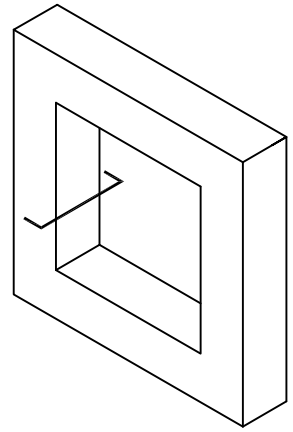

VELFAC Ltd
Tel. +44 1223 897100
Fax. +44 1223 897101
Web. www.VELFAC.co.uk

7				Scale.	1:2.5/A4
6				Date.	Feb 10
5				Drawn By.	iDS
4				Checked By.	J.R.
3	03/12	SDS	External weatherseal, cill downstand	Project No.	-
2	20/10	iDS	VELFAC Twist-In Lug Introduced	Dwg No.	
1	05/10	iDS	1st Issue		200.Bwk.J002
Rev.	Week/Year	Sign.	Description	Edition No.	2

Title
VELFAC 200 SYSTEM
Typical Brickwork Jamb Interfaces
TIMBER FRAME CONSTRUCTION