

Notes:

Method For Cill Attachment: -

- Apply silicone to attachment profile
- Apply pu foam to timber surround
- Apply cill pressing
- Apply silicone bead at each end of cill to fully seal to structure*

EXTERNAL WEATHER SEAL

Compressible Impregnated Tape Seal, Size To Suit Finished Joint In Accordance With Manufacturers Recommendations

- DENOTES AIR SEAL LINE
- - - - - DENOTES WEATHERSEAL LINE

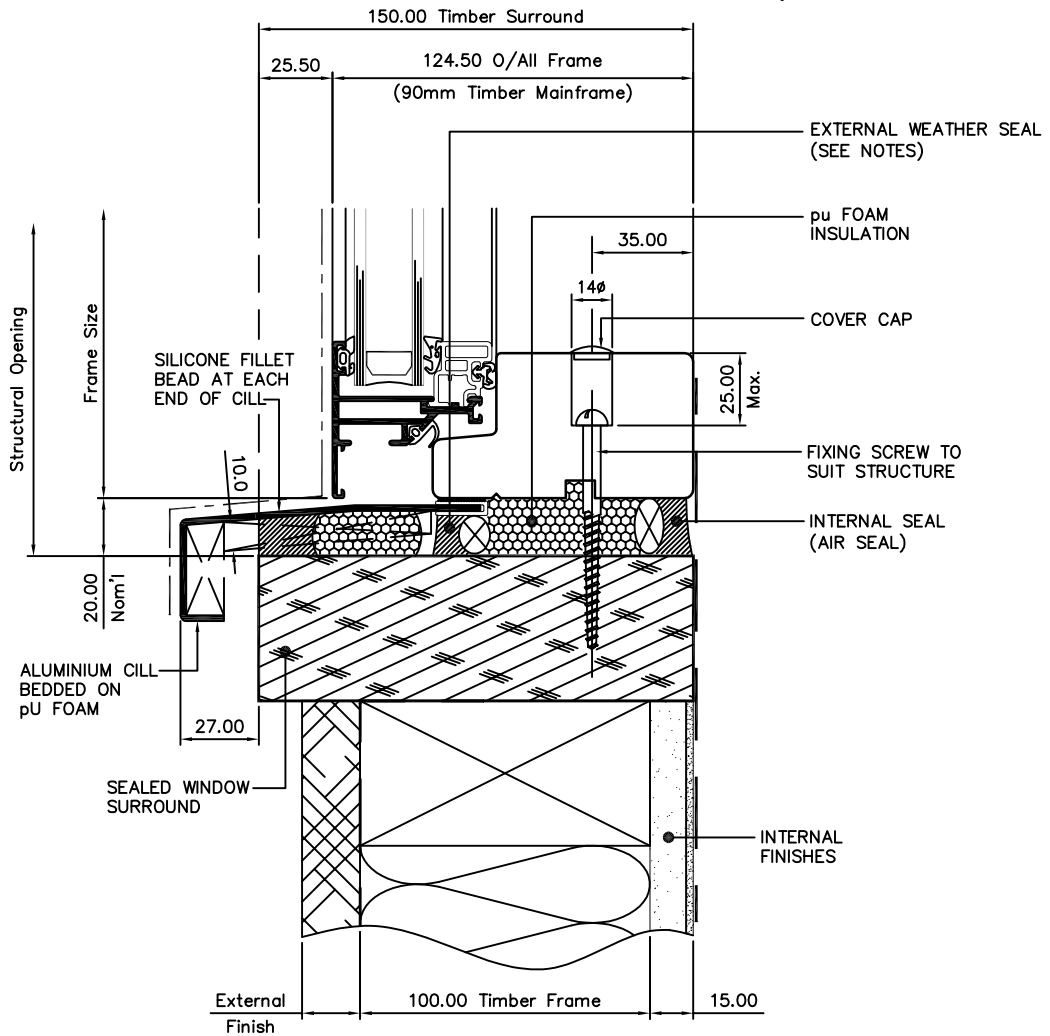
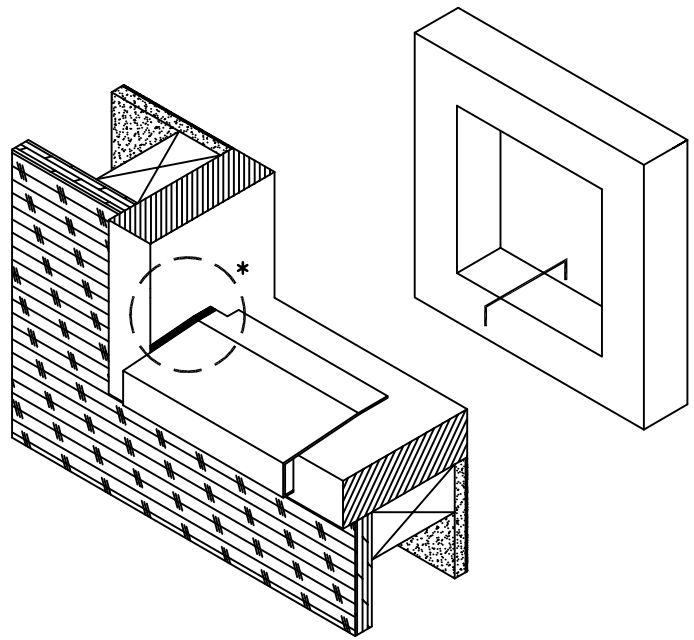
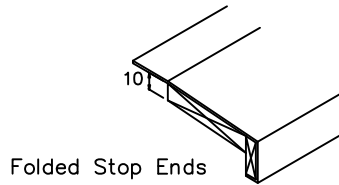

VELFAC Ltd
 Tel. +44 1223 897100
 Fax. +44 1223 897101
 Web. www.VELFAC.co.uk

Title

VELFAC 200 SYSTEM
 Typical Timber Surround Cill Interface
 With Aluminium Cill

7				Scale.	1:2.5/A4
6				Date.	Apr 11
5				Drawn By.	iDS
4				Checked By.	J.R.
3				Project No.	-
2	03/12	SDS	Ext.weatherseal line,cill downstand,20mm tol	Dwg No.	200.TimSur.C001
1	15/11	iDS	1st Issue		
Rev.	Week/Year	Sign.	Description	Edition No.	1

This drawing must not be used or copied without the permission of VELFAC LTD

Notes:

EXTERNAL WEATHER SEAL

Compressible Impregnated Tape Seal, Size To Suit
Finished Joint In Accordance With Manufacturers
Recommendations

- — — — — DENOTES AIR SEAL LINE
- - - - - DENOTES WEATHERSEAL LINE

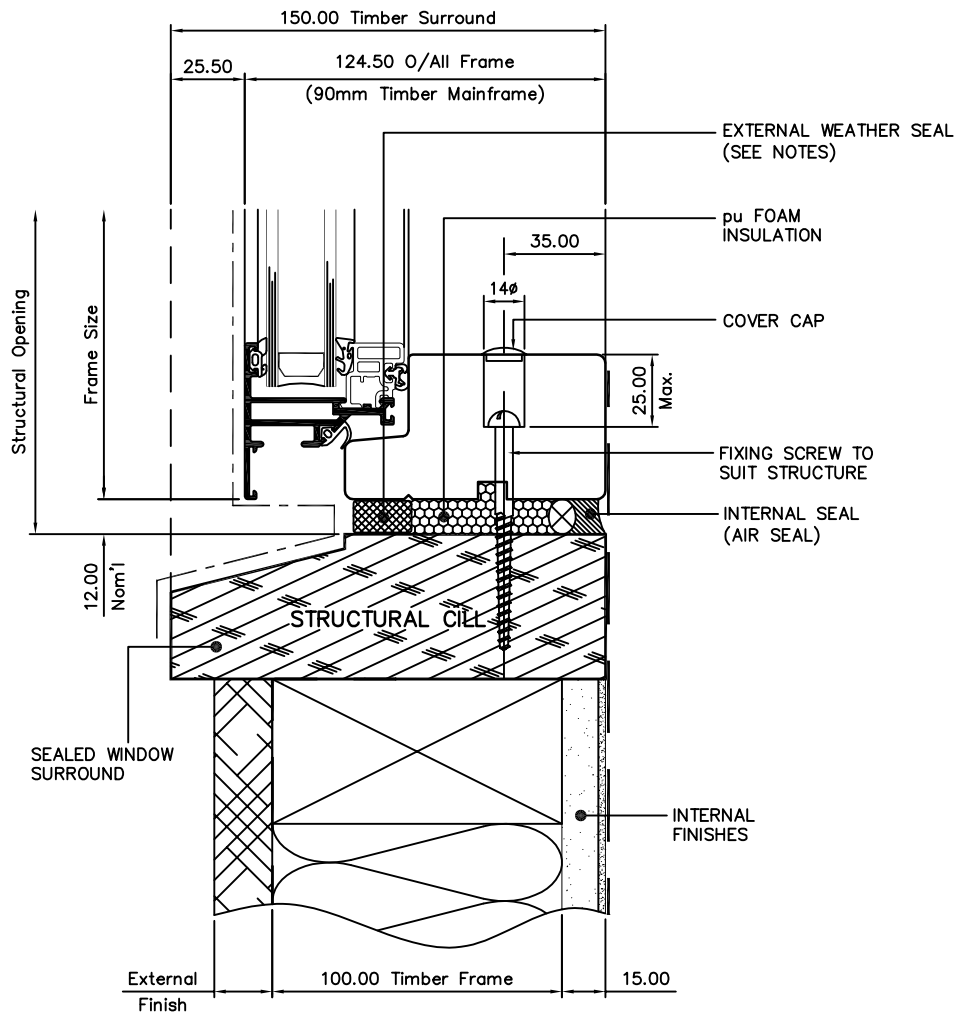
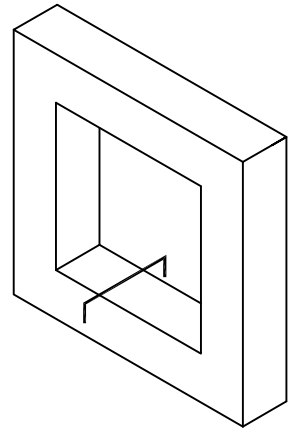

VELFAC Ltd
Tel. +44 1223 897100
Fax. +44 1223 897101
Web. www.VELFAC.co.uk

Title

VELFAC 200 SYSTEM
Typical Timber Surround Cill Interface
With Structural Cill

7				Scale.	1:2.5/A4
6				Date.	Apr 11
5				Drawn By.	iDS
4				Checked By.	J.R.
3				Project No.	-
2	03/12	SDS	External weatherseal line added	Dwg No.	200.TimSur.C002
1	15/11	iDS	1st Issue	Edition No.	1
Rev.	Week/Year	Sign.	Description		

This drawing must not be used or copied without the permission of VELFAC LTD

Notes:

EXTERNAL WEATHER SEAL

Compressible Impregnated Tape Seal, Size To Suit
Finished Joint In Accordance With Manufacturers
Recommendations

- — — — — DENOTES AIR SEAL LINE
- - - - - DENOTES WEATHERSEAL LINE

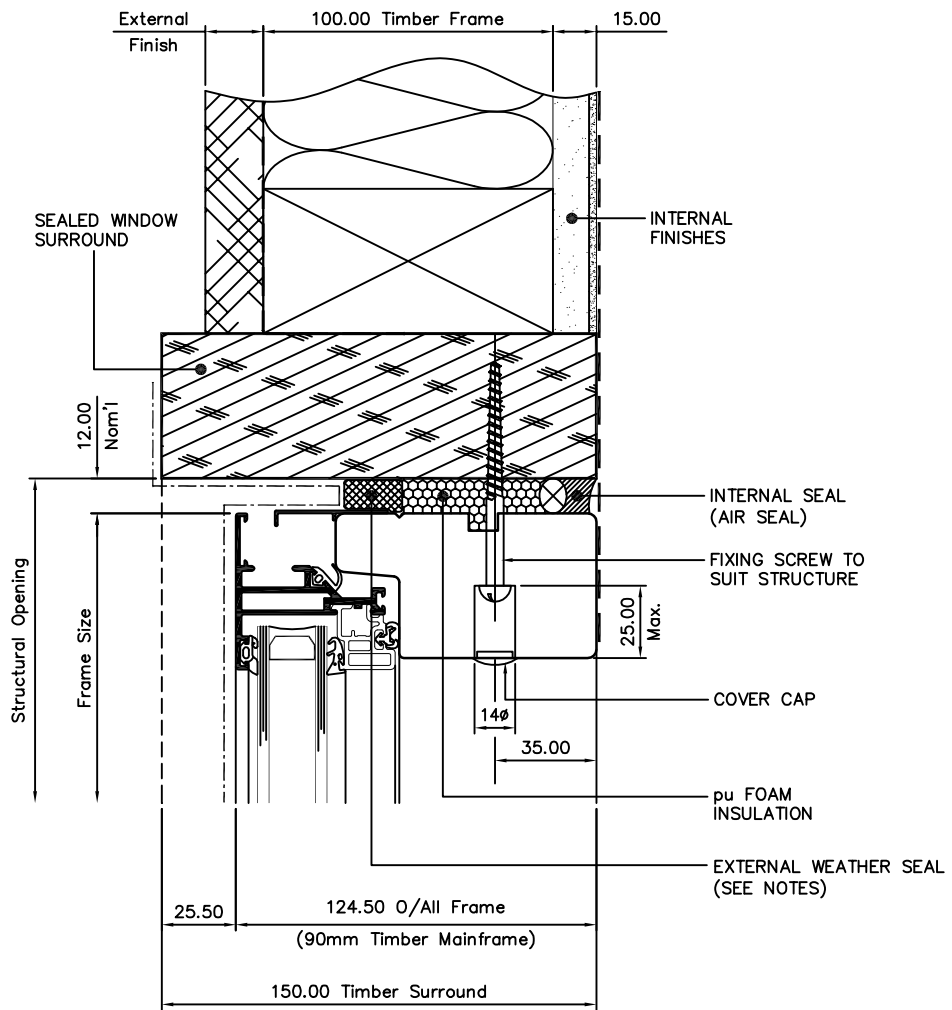
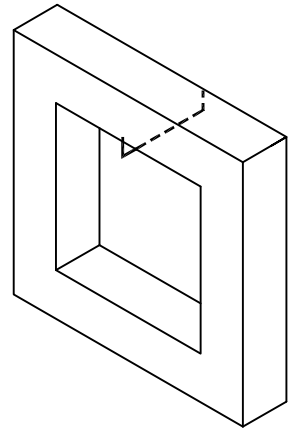

	VELFAC Ltd Tel. +44 1223 897100 Fax. +44 1223 897101 Web. www.VELFAC.co.uk		7			Scale.	1:2.5/A4
			6			Date.	Apr 11
			5			Drawn By.	IDS
			4			Checked By.	J.R.
			3			Project No.	-
Title VELFAC 200 SYSTEM Typical Timber Surround Head Interface			2	03/12	SDS	External weatherseal line added	Dwg No. 200.TimSur.H001
			1	15/11	IDS	1st Issue	
		Rev.	Week/Year	Sign.	Description	Edition No.	1
This drawing must not be used or copied without the permission of VELFAC LTD							

Notes:

EXTERNAL WEATHER SEAL

Compressible Impregnated Tape Seal, Size To Suit
Finished Joint In Accordance With Manufacturers
Recommendations

- — — — — DENOTES AIR SEAL LINE
- - - - - DENOTES WEATHERSEAL LINE

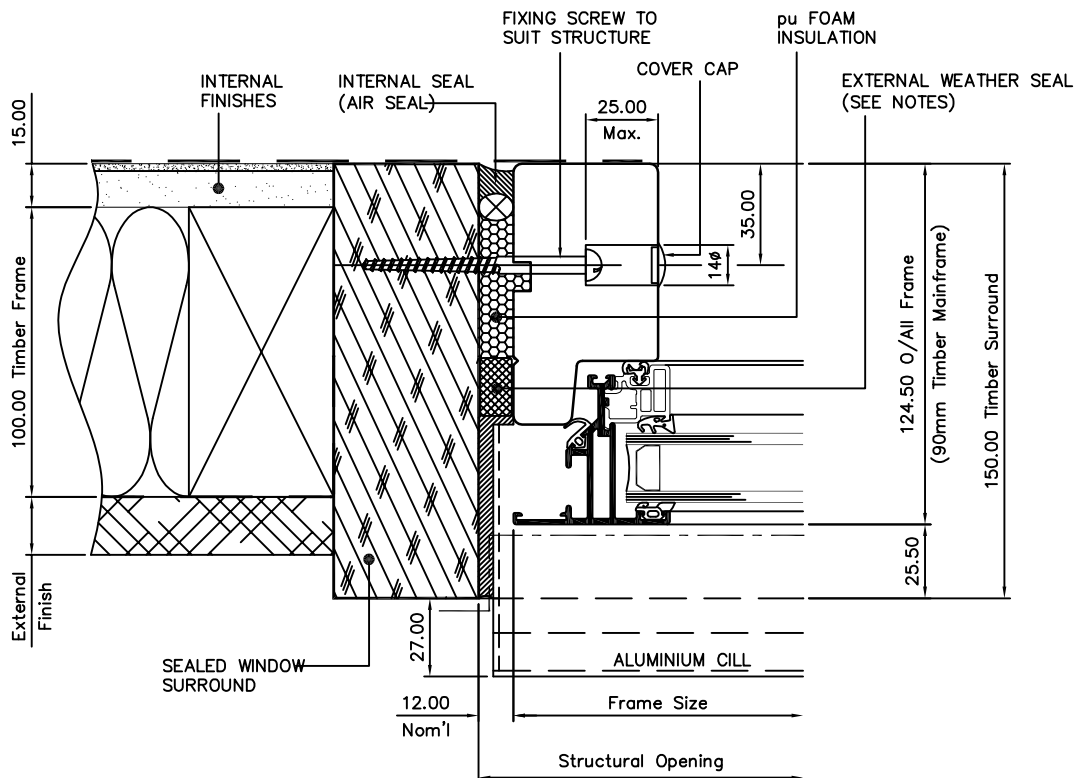
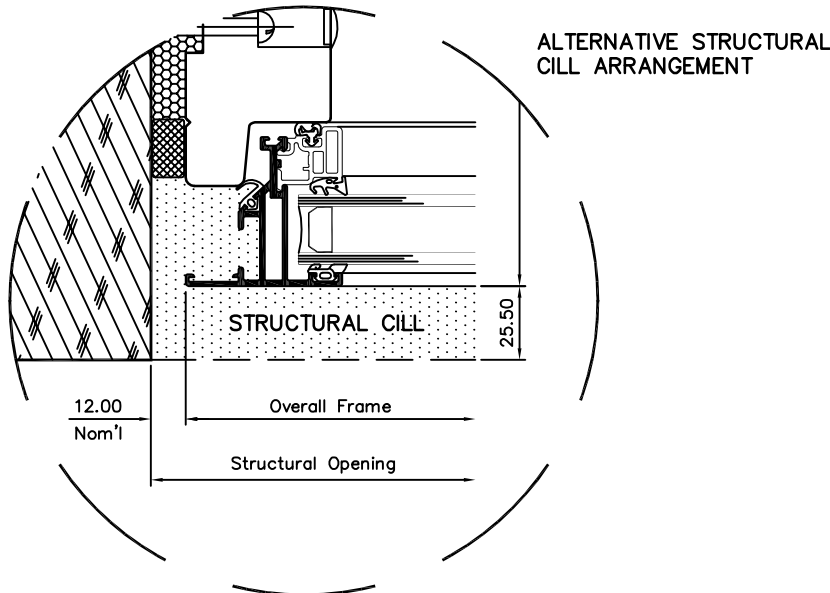
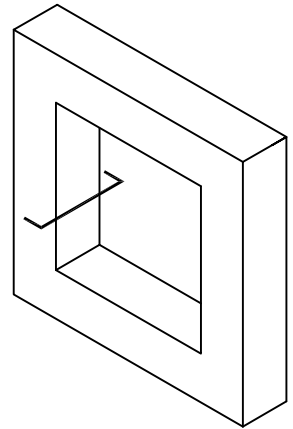

VELFAC Ltd
Tel. +44 1223 897100
Fax. +44 1223 897101
Web. www.VELFAC.co.uk

Title
VELFAC 200 SYSTEM
Typical Timber Surround Jamb Interface

7				Scale.	1:2.5/A4
6				Date.	Apr 11
5				Drawn By.	iDS
4				Checked By.	J.R.
3				Project No.	-
2	03/12	SDS	Ext.weatherseal line,cill downstand added	Dwg No.	200.TimSur.J001
1	15/11	iDS	1st Issue		
Rev.	Week/Year	Sign.	Description	Edition No.	1

This drawing must not be used or copied without the permission of VELFAC LTD